

## Introduction

Quantum computing uses non-classical properties, including superposition, entanglement, and interference, to solve a variety of problems in innovative ways, reducing computational costs and storage requirements. Thus, we propose:

1. Develop the **(First)** quantum approach for integer wavelet transforms.
2. **Three main wavelets:** Haar, CDF, and DB4.
3. Quantum lossless compression application.

## Problem Setting

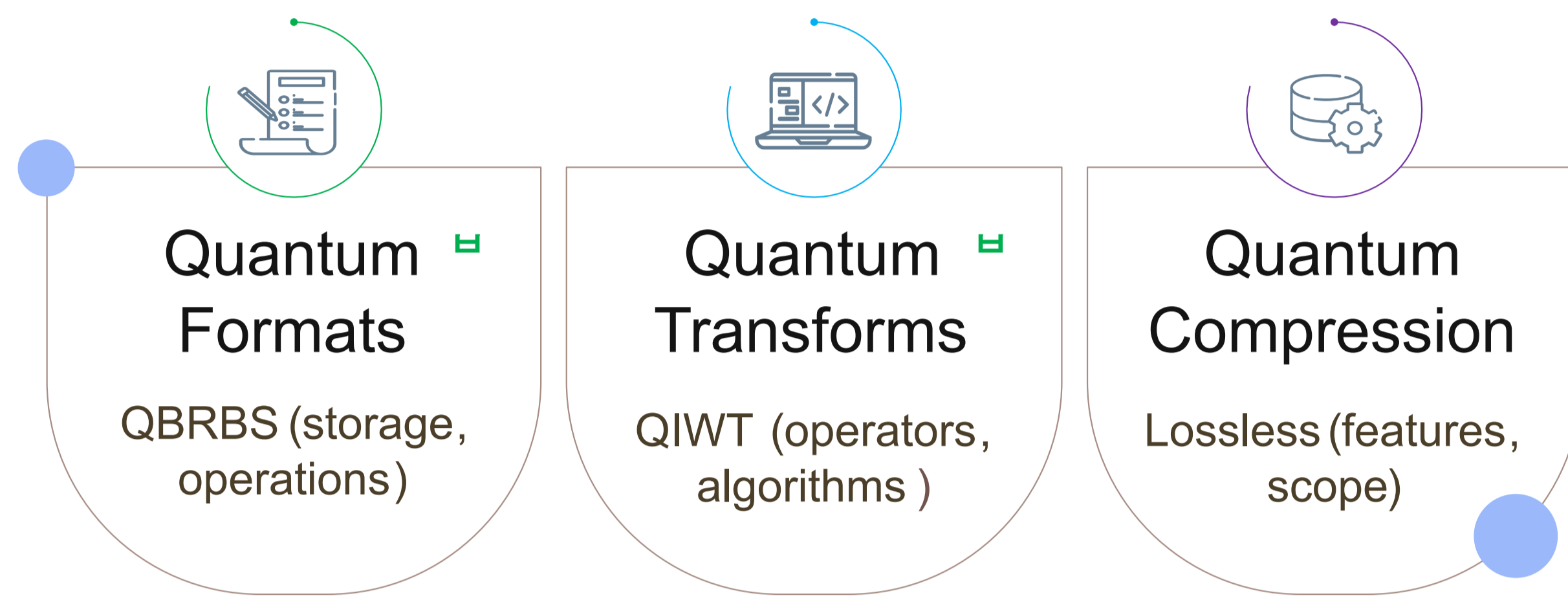

Figure 1. Quantum research roadmap.

## Objectives

**General Objective:** Propose a quantum approach for the one-dimensional integer wavelet transform for Haar, Daubechies-4 (DB4), and CDF kernels for quantum signal decomposition and quantum lossless compression.

### Specific Objectives

1. To identify the factorization matrices that characterize the unitary operators for the one-dimensional quantum integer wavelet transform. ✓
2. To analyze and select a quantum format to represent one-dimensional signals that allows signal decomposition. ✓
3. To develop a quantum algorithm for one-dimensional signal decomposition using the proposed quantum transform. ✓
4. To develop a quantum lossless compression algorithm based on the proposed quantum integer wavelet transforms.

## Quantum Compression

- **Classical:** compress information data for transmission (increasing channel capacity) and/or storage (reducing the number of bits).
- **Quantum:** reduce the number of qubits for storage, limit the quantum resources (gates), and minimize the measurements.
- **Lossless and lossy** techniques are also used in quantum compression.

## Issues: Quantum Compression

- Variable length encoding of codewords (Huffman, Arithmetic) cannot be used directly (**non-orthogonal**) - Classical methods do not work in the same way [1].
- Measuring (**retrieving**) all information data requires multiple copies of the input signal [2,3]
- Early stage of quantum noise and error correction (**limited lossless compression**) [3].

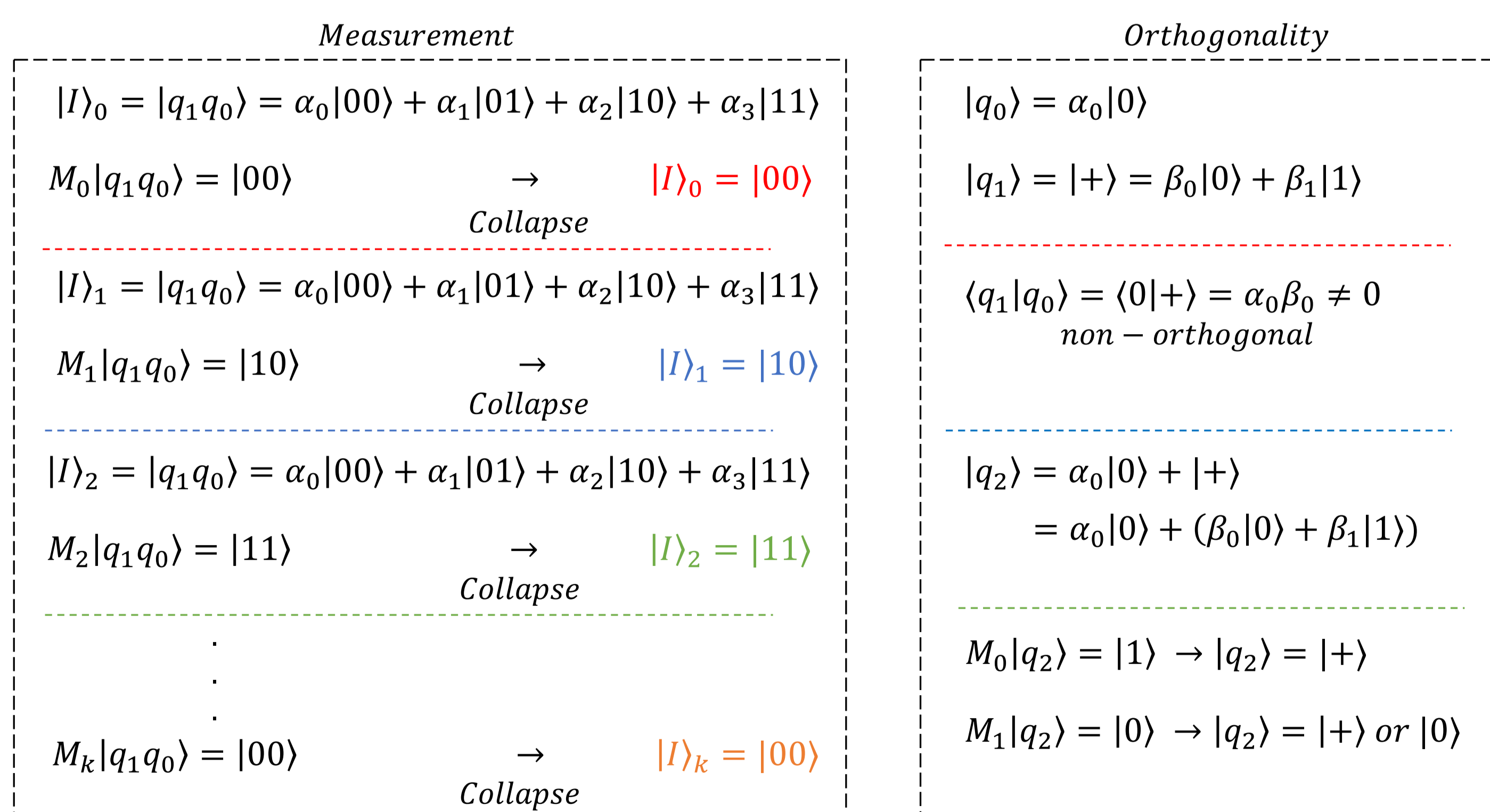

Figure 2. Quantum compression issues.

## References

- [1] Müller, M., Rogers, C., & Nagarajan, R. (2009). Lossless quantum prefix compression for communication channels that are always open. *Physical Review A*, 79(1), 012302. [2] Bostroem, K., & Felbinger, T. (2002). Lossless quantum data compression and variable-length coding. *Physical Review A*, 65(3), 032313. [3] Ruan, Y., Xue, X., & Shen, Y. (2021). Quantum image processing: opportunities and challenges. *Mathematical Problems in Engineering*, 2021, 1-8.

## Approaches: Quantum Compression

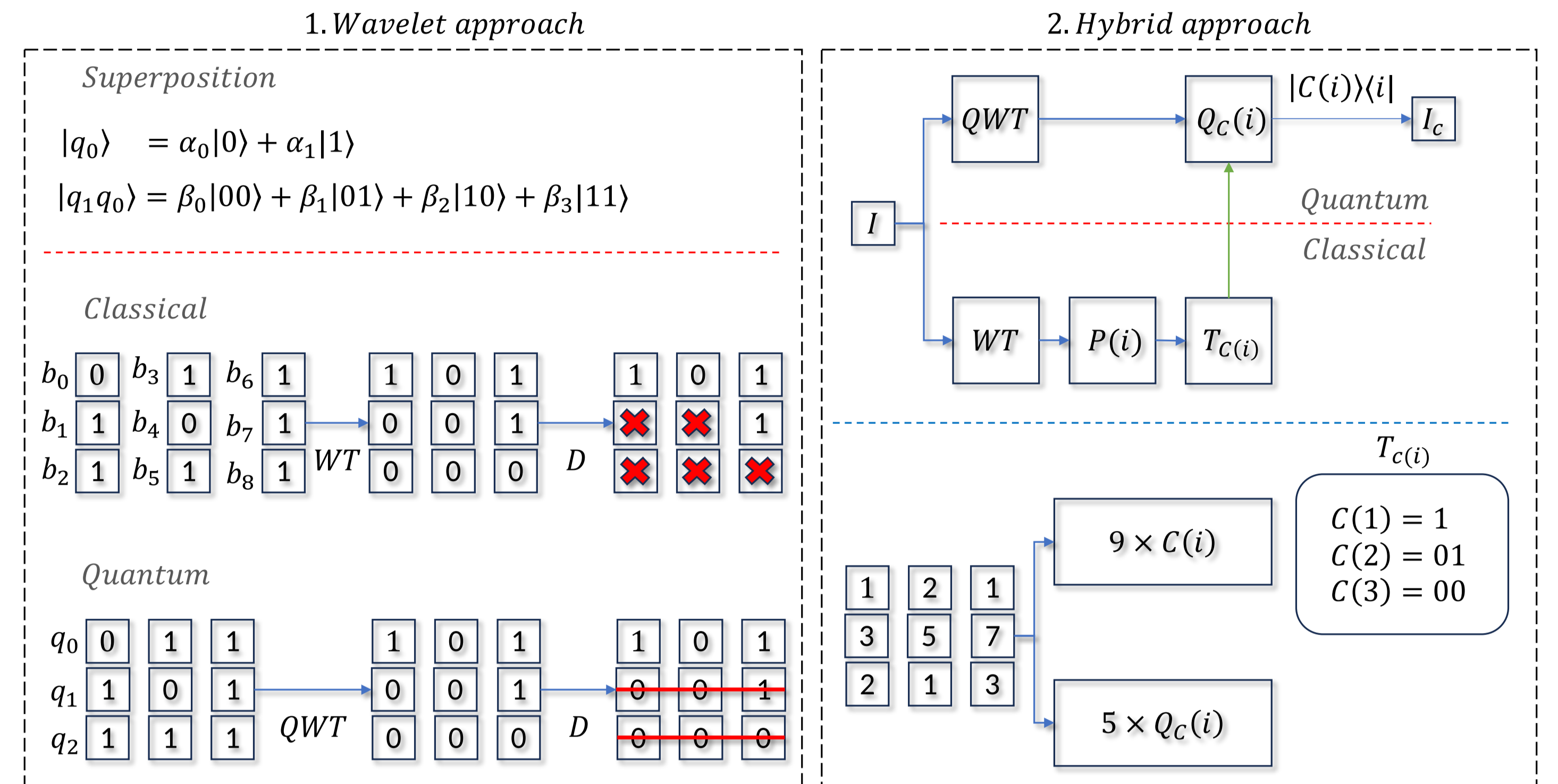

Figure 3. Quantum compression approaches.

## Simulation Results

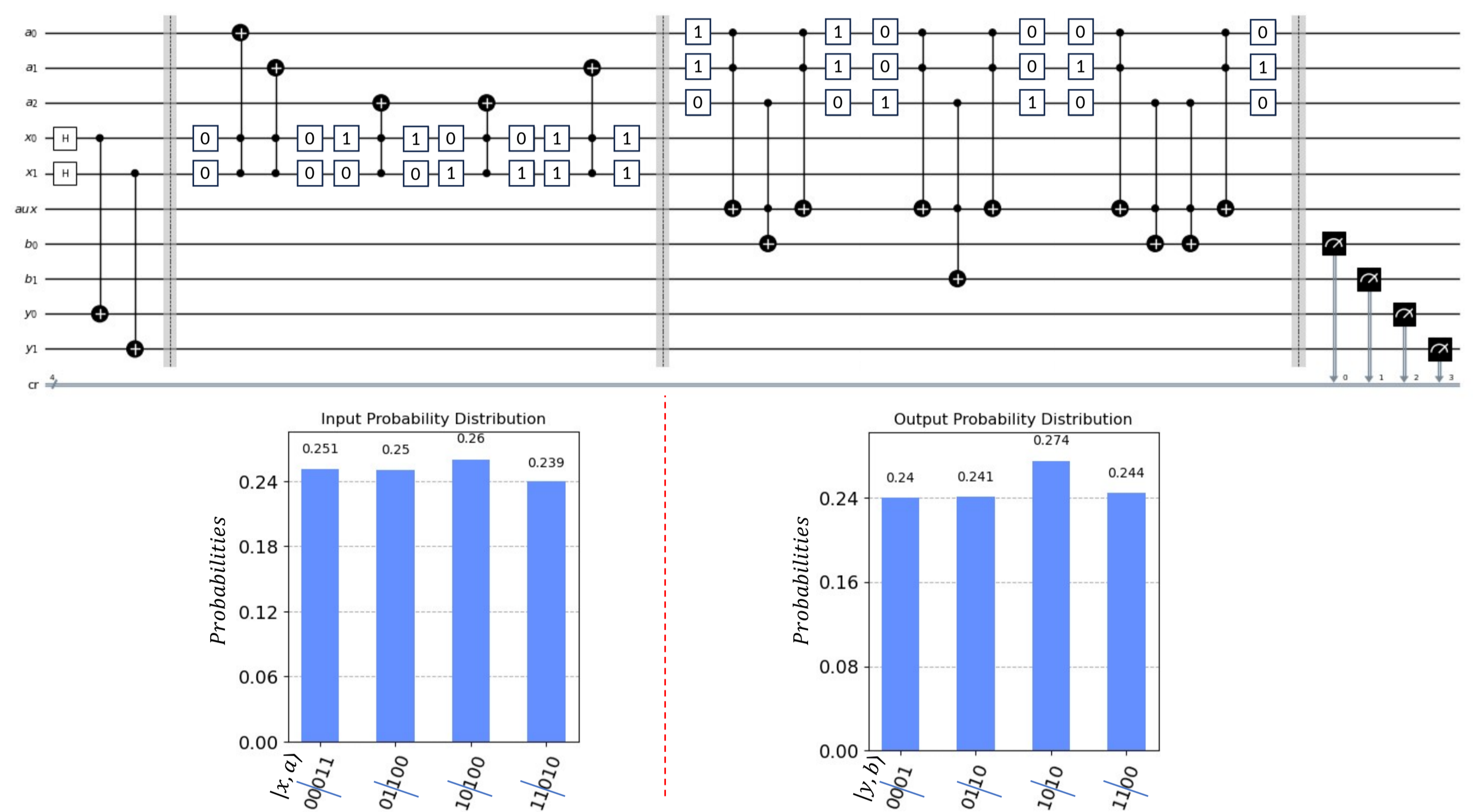

Figure 4. Quantum codeword circuit simulation.

## Contributions and Future Activities

### Contributions

- Qbrbs: Quantum block representation by basis states. *QCE* (2022) (pp. 125-132). IEEE. - **Published**.
- QIST: One dimensional quantum integer wavelet S-transform. *Information Sciences* (2023), 622, 999-1013. - **Published**.
- Quantum Integer CDF Wavelet Transforms (*Information Science* (2023) - Elsevier) - **Under review**.
- Quantum Operations on Superposed States (*Journal of Network and Computer Applications* - Elsevier) - **Advisors review**.

### Future Activities

- Develop quantum lossless compression algorithm - **In progress**.
- Write the thesis document - **In progress**.
- Submit paper (Superposed Operations).
- Quantum DB4 (*Journal*), Quantum compression application (*Journal*), Quantum denoising (*Conference*).

## Research Timeline

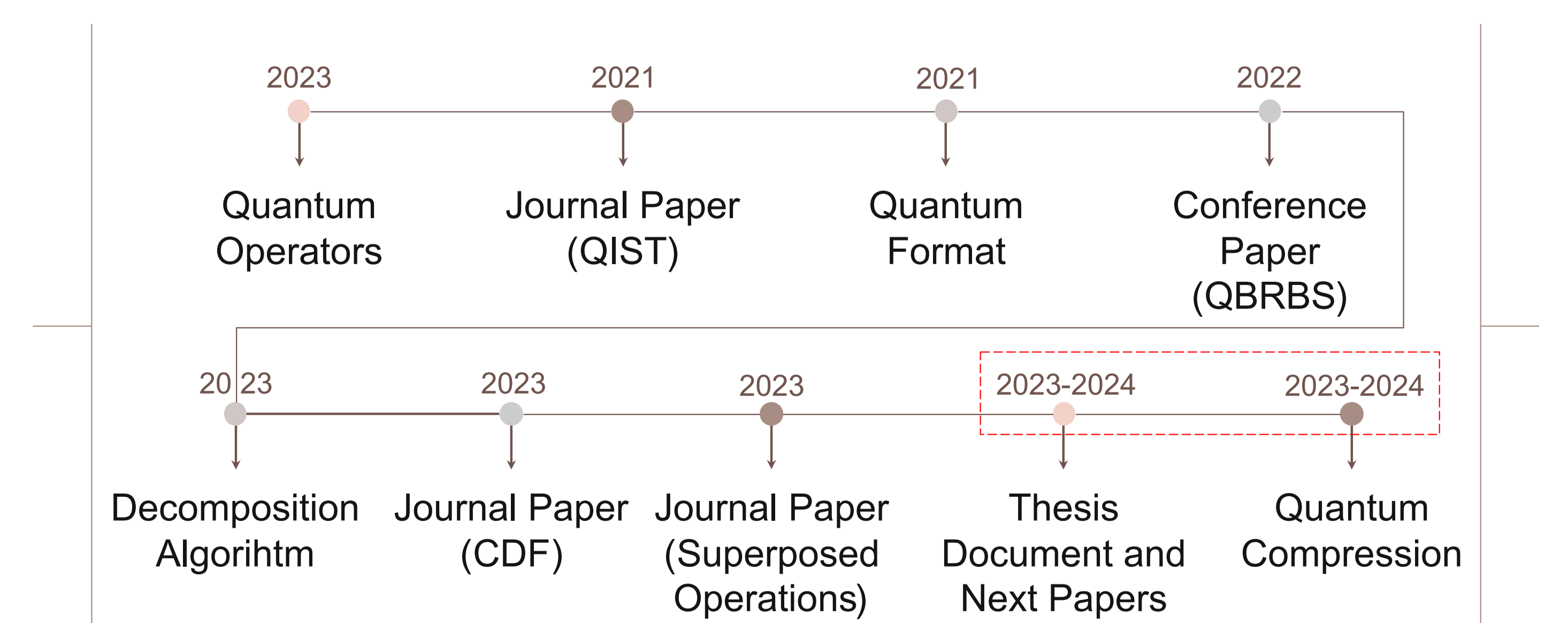

Figure 5. Research work timeline.