

Multi-objective Optimization of Water-using Systems

Carlos E. Mariano-Romero and Víctor H. Alcocer-Yamanaka
Hydraulics Department,
Mexican Institute of Water Technology,
Paseo Cuahunáhuac 8532, Progreso, Jiutepec, Mexico
{*cmariano, valcocer*}@tlaloc.imta.mx,
Eduardo F. Morales
INAOE,
Luis Enrique Erro No. 1, Santa María Tonantzintla,
Puebla, 72840, Mexico
emorales@inaoep.mx

Abstract

Industrial water systems often allow efficient water uses via water reuse and/or recirculation. The design of the network layout connecting water-using processes is a complex problem which involves several criteria to optimize. Most of the time, this design is achieved using Water Pinch technology, optimizing the freshwater flow rate entering the system. This paper describes an approach that considers two criteria: (i) the minimization of freshwater consumption and (ii) the minimization of the infrastructure cost required to build the network. The optimization model considers water reuse between operations and wastewater treatment as the main mechanisms to reduce freshwater consumption. The model is solved using MDQL (*Multi-objective Distributed Q-Learning*), a heuristic approach based on the exploitation of knowledge acquired during the search process. MDQL has been previously tested on several multi-objective optimization benchmark problems with promising results [16]. In order to compare the quality of the results obtained with MDQL, the reduced gradient method was

applied to solve a weighted combination of the two objective functions used in the model. The proposed approach was tested on three cases: (i) a single contaminant four unitary operations problem where freshwater consumption is reduced via water reuse, (ii) a four contaminants real-world case with ten unitary operations, also with water reuse, and (iii) the water distribution network operation of Cuernavaca, Mexico, considering reduction of water leaks, operation of existing treatment plants at their design capacity, and design and construction of new treatment infrastructure to treat 100% of the wastewater produced. It is shown that the proposed approach can solve highly constrained real-world multi-objective optimization problems.

1 Introduction

Water pinch technology (WPT) evolved out of the broader concept of process integration of materials and energy and the minimization of emissions and wastes in chemical processes. WPT can be seen as a type of mass-exchange integration involving water-using operations, that enables practicing engineers to answer important questions when retrofitting existing facilities and designing new water-using networks. There are three basic tasks in WPT: a) identification of the minimum freshwater consumption and wastewater generation in water-using operations (analysis), b) water-using network design to comply with the flow rate targets for freshwater and wastewater through water reuse, regeneration, and recycle (synthesis), and c) modification of an existing water-using network to maximize water reuse and minimize wastewater generation through effective process changes (retrofit).

Nowadays most WPT problems are formulated as non linear highly restricted programming problems [1, 13, 14]. Important efforts have aimed to make the mathematical models more robust and applicable to real world problems [2, 7, 10]. Other efforts have aimed to apply WPT technology to other fields such as design and retrofit of urban distribution systems [3].

In general, WPT traditionally minimizes freshwater flow rate entering a system, using mass balance and the concentrations of contaminants at the inlet and outlet in all water-using operations as restrictions. Because of the diverse types of water-using operations, treatment effectiveness and cost, and types of contaminants, the criteria for efficient use of water is inherently non linear, multiple and conflicting [2, 10, 13]. Some of the criteria that can easily be identified are: equipment cost minimization, maximization of reliability

(amount of contaminant captured at treatment plants) and minimization of wastewater production.

This paper describes a mathematical formulation that extends WPT analysis with elements of capital cost of the required pipe work. Consequently, the optimization is based on cost efficient networks and networks featuring freshwater consumption. The model involves two criteria: (i) the minimization of freshwater consumption and (ii) the minimization of infrastructure costs. Two techniques are used to solve this problem: 1) weighted aggregation considering variation in the weight coefficients in order to construct the Pareto set and using a reduced gradient method, and 2) *MDQL*, a heuristic approach based on the exploitation of the knowledge generated during the search process. Results obtained with both approaches are compared with solutions reported in the literature for the solution of the single-objective problem that minimizes the freshwater flow rate entering the system.

The proposed multi-objective optimization model was applied to three test cases: a) Four water-using operations and single contaminant, b) ten water-using operations and four contaminants and c) Cuernavaca's water distribution network operation considering two different strategies: c.1) reduction of leaks in the network and operation of wastewater treatment plants at their design capacity, and c.2) reduction of leaks in the network, operation of wastewater treatment plants at their design capacity, and construction of new treatment infrastructure to reach 100% wastewater treatment. It is shown that the highly constrained subjective optimization real-world problems can be solved with MDQL.

Section 2 presents the mathematical formulation for the bi-objective optimization problem. In Section 3 the weighted aggregation method and the MDQL heuristic approach are described. Section 4 describes the three cases under study and discusses the main results. Section 5 gives conclusions and future research directions.

2 Mathematical formulation

The mathematical model describing an industrial water demanding process considers two main components: a) the available freshwater sources to satisfy demands, and b) the water-using operations described by loads of contaminants and concentration levels. An example of two sources and two operations is sketched in Figure 1. This figure represents with rectangles

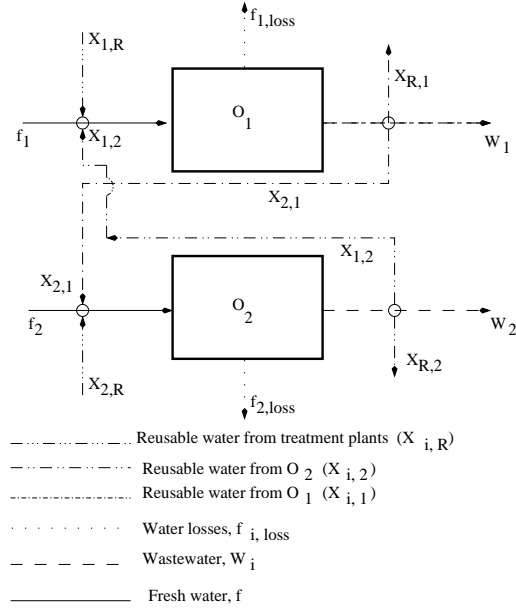

Figure 1: Block diagram of a water-using system with two sources and two operations.

the two unitary operations (O_i), and with solid lines on the left side of the operations their corresponding freshwater demands (f_i). Wastewater from operations are represented with dashed lines on the right side of operations. The rest of the connections represent all the potential links between unitary operations (water reuse), leaks, and treatment plants. The direction arrow heads at the end of lines indicate the direction of flux.

The design task is to find the network configuration that minimizes the overall demand for freshwater, $\sum f_i$, (and consequently reduce the wastewater volume $\sum W_i$) compatible with minimum investment cost. In order to complete the design task, the optimization problem is stated in terms of low freshwater consumption, a suitable network topology for water reuse, $X_{i,j}$, and a low investment cost.

Unitary operations of demanded water are defined through their contaminant loads, required flow rates, and allowable minimal and maximal contaminant concentrations at influxes and discharges.

The objective functions for freshwater consumption minimization and for infrastructure minimization are represented by Equations 1 and 2.

$$MinZ_1 = F_1 = \sum_j cst_j + TPC, \quad (1)$$

$$MinZ_2 = F_2 = \sum_i f_i \quad (2)$$

Where: F_1 is the total cost of the distribution network considering the connection of freshwater sources to unitary operations receiving water directly, and the connection for reusing water between unitary operations. The total distribution network cost is composed by the sum of the partial costs, cst_j , of the pipe segments used for connecting freshwater sources to unitary operations and unitary operations to unitary operations, and TPC , the treatment plant construction cost that applies only for new treatment infrastructure. In F_1 we are not considering maintenance and rehabilitation costs.

F_2 , is the total freshwater demanded by the system, obtained by the partial demands of freshwater from each of the unitary operations in the system. Partial demands from unitary operations, say operation O_i , are represented as f_i . That is f_i is the partial freshwater demand of operation O_i .

2.1 Infrastructure cost

Evaluation of the first objective function, F_1 , depends only on the pipe segment costs in the network. These costs are represented as cst_j , and depend on three variables (see Equation 3): a) pipe length, L_j ; b) cost per unit length, PC_j ; which depends on the pipe diameter required to transport the demanded flow of water, D_j ; and c) a cost factor, CF_j , related to pipe materials required to resist corrosive effects of contaminants. It is important to note that the main objective of this work is to demonstrate the benefits obtained by the solution of the multi-objective approach, compared with those obtained with a single objective approach. For this reason, some considerations regarding the hydraulic behavior of the network are not included.

$$cst_j = L_j \times PC_j \times CF_j \quad (3)$$

As previously mentioned, PC_j depends on the minimum pipe diameter, $D_j = f(Q_j)$, required to transport the water flow through the pipe. The minimum diameter, D_{min_j} , is obtained applying Equation 4; deduced from

Table 1: Cost per unit length for commercial diameter pipes.

Diameter (mm)	PC \$/m
99	4.8
150	5.0
200	8.9
250	12.9
300	17.7
350	23.6
400	25.6
450	34.1
500	40.9
610	42.6
762	45.9
838	54.6
1,016	69.9
1,118	83
1,219	94
1,372	110

the definition of flow ($Q = velocity/area$) considering maximum velocities of water in pipes of $2.5m/s$. D_{min_j} is approximated to the closest upper commercial diameter. Table 1 shows diameters and cost per unit length for commercial pipes considered in this work. The data in Table 1 is only demonstrative and can be substituted with real data from local markets.

$$D_{min} = 0.714\sqrt{Q} \quad (4)$$

where: D_{min} is the minimal pipe diameter in mm required to transport flow rate Q ; $Q \in \{f_i, X_{i,j}, W_i\} \forall i, j$ and is given in m^3/s .

In a similar manner, the factor CF_j is related to the capacity of the pipe segments to resist corrosive effects due to the presence of contaminants in water flows. Values for the CF_j factor are included in Table 2, calculated considering local prices in Mexico for non corrosive pipes.

Finally the treatment plant construction cost considered in this work is $10\$/l$, that is the construction cost in monetary units per liter of treatment capacity for the plant or plants.

Table 2: Cost factors for pipes resistant to abrasive effects of contaminants.

Contaminant concentration (mg/l)	CF
$0 \leq c \leq 50$	1.25
$50 < c \leq 100$	1.5
$100 < c \leq 150$	2.0
$150 < c \leq 200$	3.0
$200 < c \leq 500$	5.0
$500 < c$	10.0

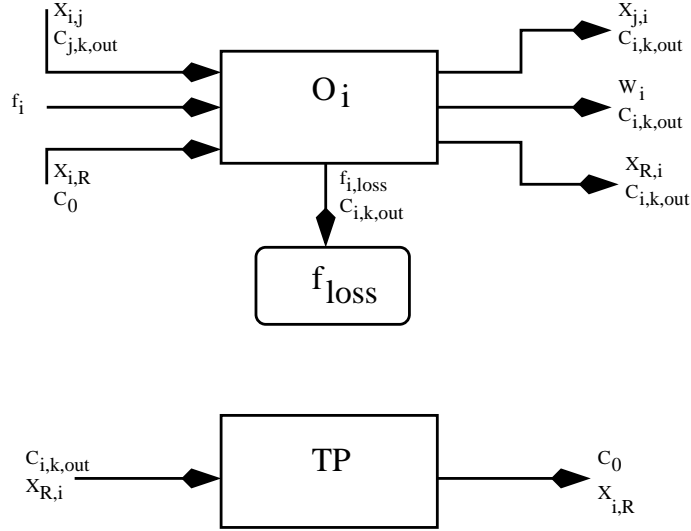

Figure 2: General structure for mass balance.

2.2 Freshwater demand

To guarantee steady state conditions in the system, it is necessary to restrict the objective functions by the mass balance between unitary operations, and by the maximum and minimum allowed contaminant concentrations on the inffluxes and discharges of operations [14].

The flow-rate required in each unitary operation is related to the mass load of contaminants ($\Delta m_{i,k,tot}$) discharged by operations. This is described in Equation 5.

$$f_i = \max_c \frac{\Delta m_{i,k,tot}}{c_{i,k,out}^{max} - c_{i,k,in}^{max}} \quad (5)$$

where f_i is the freshwater flow rate for operation O_i ; $\Delta m_{i,k,tot}$ is the total mass transfer for each contaminant, k , to the water used at operation O_i (this term is also known as the contaminant mass charge [3] and is expressed in kg/h); $c_{i,k,out}^{max}$ and $c_{i,k,in}^{max}$ are the maximum allowed concentration of contaminant k on the discharge and influx of operation O_i , in mg/l respectively.

The optimization model depends on the mass balance between all inlets and all outlets of water to the operation O_i . According to Figure 2, the expression for the mass balance has the form shown in Equation 6.

$$f_i + \sum_{j \neq i} X_{i,j} + X_{i,R} - f_{i,loss} - W_i - \sum_{j \neq i} X_{j,i} - X_{R,j} = 0 \quad (6)$$

where, $X_{i,j}$ is the reusable water flow rate from other operations, say O_j , in operation O_i ; $X_{i,R}$ is the treated water from the wastewater treatment plants that can be used in operation O_i ; $f_{i,loss}$ is the portion considered as water loss in the operation or water consumption by the operation; W_i is the wastewater flow rate from operation O_i ; $X_{j,i}$ is the reusable water flow rate from operation O_i in operations O_j ; and $X_{R,i}$ is the portion of the discharged water from operation O_i that receives treatment. All flow-rates are represented in m^3/h . TP in Figure 2 represents a treatment plant.

k different contaminants can be considered in the optimization model. This consideration requires the definition of constraints to restrict the concentration of contaminants at the inlets and outlets of operations, in order to guarantee that water influxes will not affect the operation performance, and to avoid the violation of environmental or operation norms. The satisfaction of these constraints will determine the quantities of fresh and reused water to supply to operations. The contaminant concentration constraint at the influx of the i^{th} operation, $c_{i,k,in}$ is defined by Equation 7.

$$c_{i,k,in} = \frac{\sum_{j \neq i} X_{i,j} c_{j,k,out} + c_{k,0} X_{i,R} - f_{i,loss} c_{i,k,in}^{max}}{\sum_{j \neq i} X_{i,j} + f_i + X_{i,R} - f_{i,loss}} \leq c_{i,k,in}^{max} \quad (7)$$

where, $c_{j,k,out}$ is the concentration of contaminant, k , at the discharge of operation O_j , $c_{k,0}$ is the concentration of contaminant k in the treated water, $c_{i,k,in}$ is the maximum allowable concentration of contaminant k at the influx of operation O_i . Concentrations are expressed in mg/l .

The same way, contaminant concentration constraint at the outlet of j^{th} operation, $c_{j,k,out}$ is defined by Equation 8.

$$c_{j,k,out} = c_{i,k,in} + \frac{\Delta m_{i,k,tot}}{\sum_{j \neq i} X_{i,j} + f_i + X_{i,R} - f_{i,loss}} \leq c_{i,k,out}^{max} \quad (8)$$

Finally, non negativity constraints are established according to the following equations.

$$\begin{aligned} X_{i,j} &\geq 0, \\ f_i &\geq 0, \\ L_j \times PC_j \times CF_j &\geq 0. \end{aligned}$$

3 Solution methods

For multi-objective optimization problems there is not a single solution, but a set of non dominated solutions (*Pareto-set*), such that the quality of a solution can be improved with respect to a single criterion only by becoming worse with respect to at least one other criterion [5].

In this sense, we propose the use of two techniques especially designed to solve optimization problems with more than one criterion. The first, uses an aggregated function constructed with the use of weight coefficients representing the relative importance of the two objective functions. The resulting optimization problem is solved by the reduced gradient method for five combinations of weights to construct the Pareto set. The second technique, called *MDQL*, is a heuristic approach based on the solution of Markov decision processes [15]. MDQL is capable of exploiting the knowledge acquired during the solution process, and has been tested on several benchmark problems showing good performance (e.g., [15], [16]).

3.1 Aggregated function

This approach is probably the most known and simplest way to solve this type of problems. Some of the first references on it are [12] and [26]. The main idea is to construct a weighted combination of the objective functions. The weighted function is then used on a single objective optimization problem. In general, the weight coefficients, p_i , are real values such that $p_i \geq 0 \forall i = 1, \dots, k$ for k objectives. It is also recommended to use normalized weight

Table 3: Weight coefficient combinations used by the reduced gradient approach.

Combination	p_1	p_2
1	0.10	0.90
2	0.25	0.75
3	0.50	0.50
4	0.75	0.25
5	0.90	0.10

coefficients, so $\sum_{i=1}^k p_i = 1$. More precisely, the multi-objective optimization problem is transformed to the problem stated in Equation 9, which will be called from now on the “weighted problem”.

$$\min \sum_{i=1}^k p_i \cdot F_i \quad (9)$$

where, $p_i \geq 0 \forall i = 1, \dots, k$ and $\sum_{i=1}^k p_i = 1$.

This approach guarantees the optimality of the Pareto set if the weighted coefficients are positive or the solution is unique [18]. Pareto set construction is made with the variation of the weight coefficients values, solving the weighted problem as many times as the number of variations of the weight coefficients can be configured. This procedure can be computationally expensive and slow, although it is a simple approach to generate some Pareto solutions.

The weighted problem of the two objective functions presented in section 2, is shown in Equation 10.

$$F = p_1 \sum_i f_i + p_2 (\sum_j cst_j + TPC) \quad (10)$$

Its solution is obtained through the reduced gradient method with the use of the GAMS/MINOS program [11]. The weight coefficients combinations used are included in Table 3.

3.2 Multiple Objective Distributed Q-Learning(MDQL)

In order to efficiently solve optimization problems with more than one objective function it is desirable to use population based approaches, that is,

approaches with the capability to generate more than one solution concurrently. Moreover, it is necessary to apply the dominance optimality criterion to evaluate the generated solutions. This is the main hypothesis of much of the recently developed approaches designed to efficiently solve multi-objective optimization problems based on evolutionary computation. However, evolutionary approaches do not exploit the knowledge generated along the search process [24].

Taking advantage of some of the characteristics of evolutionary approaches, optimization problems can be solved considering the search processes of a Markov decision problem. Similar ideas have been previously used with the Ant Colony Optimization Meta-heuristic [8, 9].

MDQL considers a group of agents searching a terminal state, s_t , in an environment formed by a set of states, \mathcal{S} . The set of states, or environment is constructed with the division of the parameter space into a fixed number of parts, considering that all the decision variables can be discretized into a finite number of divisions. Each division is considered as a state, as illustrated in Figure 3. An environment with these characteristics allows the agents to propose values for each one of the decision variables in the problem.

For each state, $s \in \mathcal{S}$, a set of actions, \mathcal{A}_s , is established, see Figure 3. All state-action pairs have an associated value function, $Q(s, a)$, indicating the goodness of taking action a in state s , for reaching a terminal state $s_t \in \mathcal{S}$ (complete a task).

The search mechanism for an agent in MDQL operates when an agent located in a state selects an action based on its value function, $Q(s, a)$. Most of the times the agent selects the best evaluated action (the action with the higher estimated value for $Q(s, a)$), and sometimes a random action is selected with a probability $\epsilon \approx 0$. Action value functions are updated depending on how useful an action can be for an agent to reach a terminal state. This behavior is adjusted with the help of a reward value, $r \in \mathfrak{R}$, and the value function for the best evaluated action in the future state reached by the agent after the execution of the selected action, $Q(s', a')$. This update rule is expressed in Equation 11.

$$Q(s, a) \leftarrow Q(s, a) + \alpha \left[r + \gamma \max_{a' \in \mathcal{A}_{s'}} Q(s', a') - Q(s, a) \right] \quad (11)$$

where $Q(s, a)$ is the value function for the action, ($0 \leq \alpha \leq 1$) is the learning step, r is an arbitrary reward value, $r \in \mathfrak{R}$, γ is a discount factor, s' and a' are the next state and the best evaluated action for s' respectively.

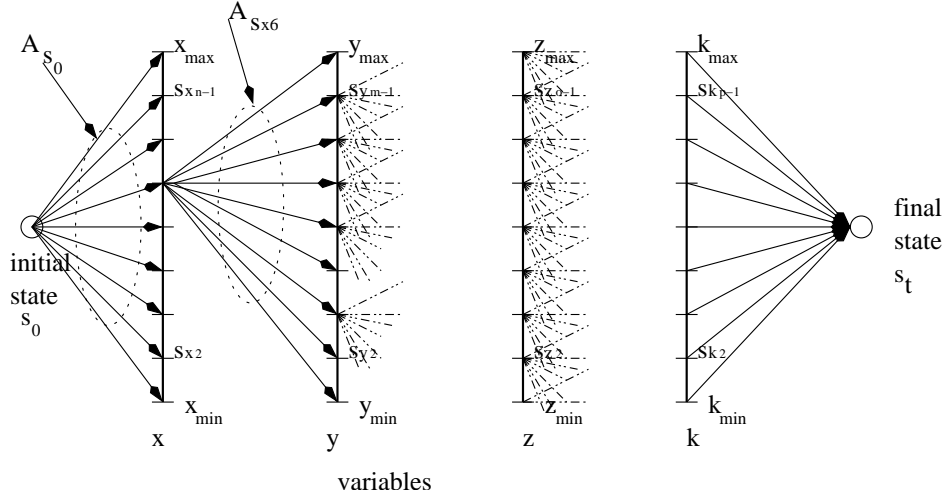

Figure 3: Variable space division for MDQL.

As an agent explores the state space, the $Q(s, a)$ estimates improve gradually, and, eventually, each $\max_{a' \in \mathcal{A}_s} Q(s', a')$ approaches: $E \{ \sum_{n=1}^{\infty} \gamma^{n-1} r_{t+n} \}$ [23]. Here r_t is the reward received at time t due the action chosen at time $t - 1$. Watkins and Dayan [25] have shown that this Q-learning algorithm converges to an optimal decision policy for a finite Markov decision process.

In *MDQL* there is a group of agents, instead of a single agent, interacting with the environment described above, and since the task for the agents is the construction of the Pareto set, the original *Q-Learning* [25] algorithm must be adapted. The main adaptations considered in *MDQL* are listed below.

- Decision variables in the environment have a predefined order, the agents move in the decision variables space obeying this order, so the definition of the values for the decision variables is made in the same order by all the agents. Each agent assigns a value for a decision variable at a time.
- When all the agents finish (set values for all the decision variables), all solutions are evaluated using the Pareto dominance criterion. Environments for non dominated solutions and solutions that violate any constraint remain in memory to be used in future episodes.
- Agents are randomly assigned to the environments in memory.

- Action values are updated in two stages. The first is made when agents make a transition using a ‘map’ of the environment. Maps are constructed making a copy of the environments in memory, and are used by agents to show to the rest of the agents the experience acquired during the search process [17]. This experience is represented by the actualization of the action value functions in the ‘map’ using the *Q-learning* rule of Equation 11. At the end of an episode and after the evaluation of solutions, non dominated solutions receive a positive reward and solutions violating any constraint receive a negative reward, which is used to update the original value functions in the environment where they were found (second stage). After the update procedure, all ‘maps’ are destroyed and a new episode initiates. More details of *MDQL* algorithm can be found in [15] and [6].

4 Test cases

The proposed mathematical model was validated and *MDQL* was tested on three cases described in the following sections. The *MDQL* operation parameters used for all test cases were: $\alpha = 0.1$, $\gamma = 0.9$, $\epsilon = 0.01$ and $r = 1$ for non dominated solutions and $r = -1$ for solutions violating constraints. Previous values for the operation parameters in *MDQL* are in some sense typical and were originally suggested in [24]. Some work related with the sensitivity of the algorithm to these parameters is presented in [16] using benchmark evaluation functions. The conclusion of the previous work indicates that the best combination of values for the operation parameters is to consider $\alpha \approx 0$, $\gamma \approx 1$ and $\epsilon \approx 0$.

4.1 Four Water Using Operations

The first test case considers four water using operations (O_1 , O_2 , O_3 , and O_4) and a single freshwater source. Table 4 shows the allowable values for freshwater, f_i , the maximum concentration at influxes, $c_{i,k,in}^{max}$, and at discharges, $c_{i,k,out}^{max}$, and the total mass transfer for contaminants, $\Delta m_{i,k,tot}$, for the four unitary operations. The objective is to find a network configuration connecting the four unitary operations to the source, with the lowest cost and the lowest freshwater consumption, considering reuse as the sole mechanism to reduce freshwater demands.

Table 4: Operation parameters for test case 1.

Operation	f (m^3/h)	$c_{i,k,in}^{max}$ (mg/l)	$c_{i,k,out}^{max}$ (mg/l)	$\Delta m_{i,k,tot}$ (g/h)
O_1	20	0.0	100.0	2,000
O_2	100	50.0	100.0	5,000
O_3	40	50.0	800.0	30,000
O_4	10	400.0	800.0	4,000

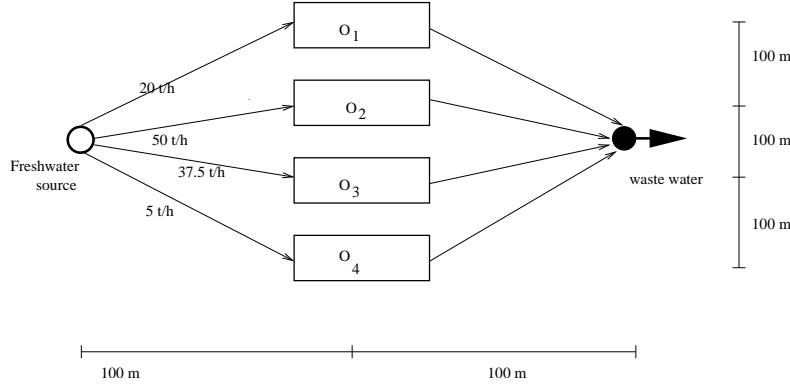

Figure 4: Non optimized solution for the first test case.

Figure 4 shows a non optimized solution where water demands in all water using operations are satisfied with freshwater, resulting in a flow of $112.5 t/h$ and with a cost of infrastructure of \$1,875.00 monetary units.

MDQL implementation for the solution of this test case considers the range and number of divisions for the variables shown in Table 5. These values represent increments of $0.2 m^3/h$ for all variables, which is the criterion used for the parameter space partition in the three problems. For example considering O_1 , with a maximum freshwater flux equal to $0 \leq f_1 \leq 20(m^3/h)$, it is divided in 100 states (each state represents a variation of $0.2m^3/h$ for f_1). The same number of divisions is considered for the rest of the variables. Each action moves the agent to a state of the next consecutive variable, i.e. assigns a value in the discretized space of the next consecutive variable. Figure 5 shows two traces of two different agents. Each of the two traces represents a solution to the optimization problem, that is a set of values for the parameters of the problem.

Twenty agents are considered for the solution of all cases. When all agents conclude an episode (definition of the 24 variables), the 20 solutions obtained

are evaluated under the dominance criterion. Non dominated solutions receive a reward value, r , used to update that state-action value function participating in its construction. The environment settings with non dominated solutions and solutions violating constraints are stored in memory and used in the next episode.

Results obtained by *MDQL* are shown in Figure 6 represented with $*$, corresponding to the best solutions found from 20 different algorithm runs with the same parameters. Figure 6 also includes the five solutions obtained by the weighted function approach, represented with \circ . As can be appreciated, *MDQL* generated more solutions over the Pareto front, 13, some of them coincide with those found by the mathematical programming approach. The solutions found by the weighted functions approach are shown in Figure 7. It is also important to notice that for this type of problem the Pareto set is small because of the restrictions.

CPU time to complete the Pareto front using the aggregated function approach and mathematical programming (solution marked with the \circ) was around 5 seconds. This time is obtained with the sum of the CPU time required to obtain each of the five solutions on the Pareto front, not considering the time required to change the weight coefficients. Besides, the average CPU time required by MDQL to define the Pareto Front presented in Figure 6 was around 8 seconds. Considering that the Pareto Front obtained by MDQL contains 13 solutions and if we extrapolate the time taken by the mathematical approach, it will require 13 seconds for the same number of solutions found by *MDQL*.

MDQL was also tested with a finer discretization ranges, the double of states per variable, obtaining the same solutions. This behavior of *MDQL* indicates that the reported Pareto set is the optimal solution for the test case considered and for this discretization level adopted.

4.2 Real industrial problem with ten operations and four contaminants

The second test case was reported by Alva-Argaez [2] and Alcocer [1]. This case was constructed with real data obtained from an industrial process in the United Kingdom, considering ten unitary operations, $O = O_1, O_2, \dots, O_{10}$, and four types of contaminants, $U = A, B, C, D$. Operation parameters are included in Table 6.

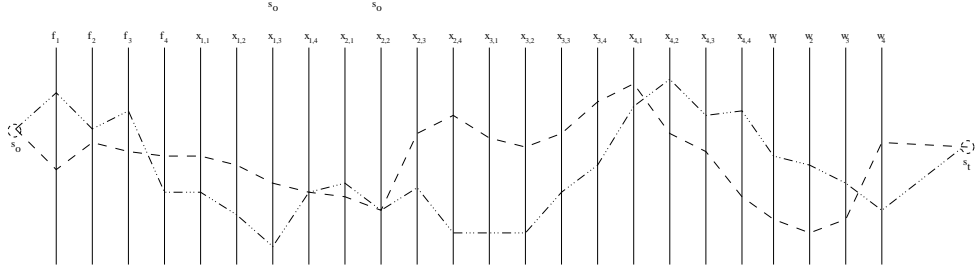

Figure 5: An example of a path taken by two agents in the MDQL implementation for the first test case.

Table 5: Variable space configuration for the first case.

Variable	Range	Number of states
f_1	0 – 20	100
f_2	0 – 100	500
f_3	0 – 40	200
f_4	0 – 10	50
$X_{1,j}; j \in 1, 2, 3, 4$	0 – 20	100
$X_{2,j}; j \in 1, 2, 3, 4$	0 – 100	500
$X_{3,j}; j \in 1, 2, 3, 4$	0 – 40	200
$X_{4,j}; j \in 1, 2, 3, 4$	0 – 10	50
W_1	0 – 20	100
W_2	0 – 100	500
W_3	0 – 40	200
W_4	0 – 10	50

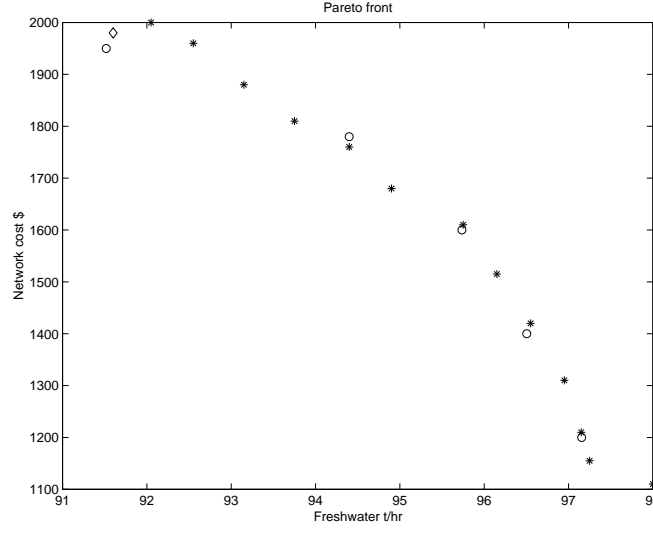

Figure 6: Pareto fronts obtained for the first test case: \circ mathematical programming solutions; $*$ MDQL solutions; \diamond solution obtained for the minimization of freshwater consumption as a sole objective.

Table 6: Operation parameters for the second test case.

Oper. O	$c_{i,j,in}^{max}(mg/l)$	$c_{i,j,out}^{max}(mg/l)$	$f(m^3/h)$
	(A-B-C-D)	(A-B-C-D)	
O_1	200-500-100-1500	25000-20000-28500-230000	24.87
O_2	350-3000-500-400	8000-9000-24080-3000	40.98
O_3	350-450-150-500	3500-2500-1500-1500	39.20
O_4	800-650-450-300	15000-5000-700-1500	4.00
O_5	1300-2000-2000-4000	2000-7000-9000-10000	3.92
O_6	3000-2000-100-0	12000-10000-8000-200	137.50
O_7	450-0-250-560	2000-3000-1000-12000	290.96
O_8	100-250-200-550	3450-4000-700-7000	23.81
O_9	150-450-3000-100	1000-1000-4000-100	65.44
O_{10}	0-0-0-0	100-100-100-100	4.00

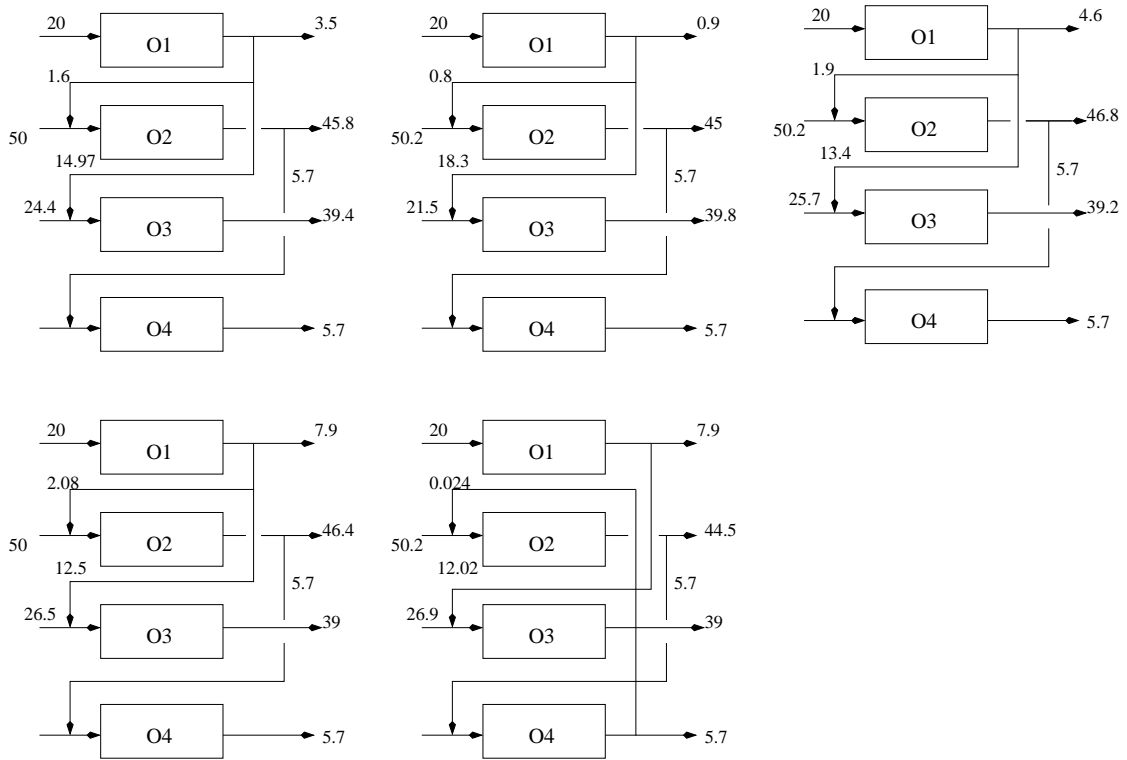

Figure 7: Solutions found with the aggregated function approach.

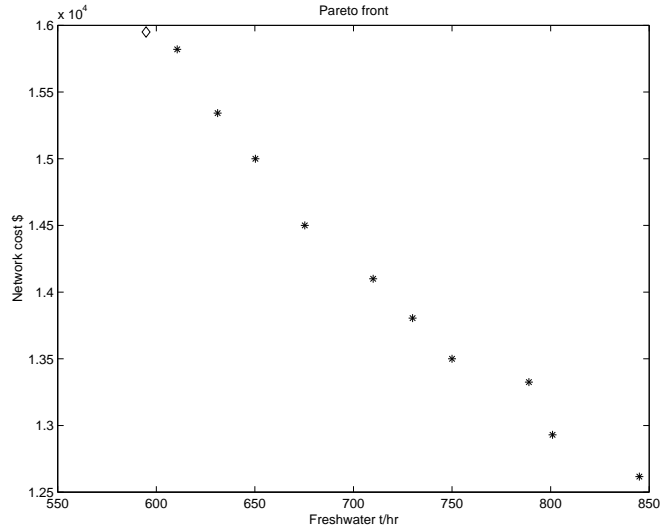

Figure 8: Solutions found by *MDQL* on the second test case * and the solution found with the a single objective model ◊.

This problem was also solved in [3] by mathematical programming considering the sole objective function of freshwater minimization. Reported results for this test case indicate that the optimal value for the objective function is $594.80m^3/h$, which is identical to the result reported in [2]. The similarity of results indicates that the two models are identical and that the results reported in this work can be compared with them.

For this second case only *MDQL* was applied due to the approximation of the Pareto fronts obtained with *MDQL* and the mathematical programming approach observed in the first case and other problems previously solved [15, 16]. Figure 8 includes the solutions obtained with *MDQL*. The solution reported in [3] is also plotted. As in the first test case, the solution for the single objective function is located in the upper left corner of the graph, the region for the lowest flow rates and highest costs. This seems logical because the solution of the optimization problem with a single freshwater minimization objective function is equivalent to a zero weight coefficient p_2 for the cost objective function Z_2 in the mathematical programming approach.

In Figure 8 it can be appreciated that the solution obtained for the single objective function (reported in [3]) is non dominated with respect to those obtained by *MDQL*, with the best evaluation for the freshwater minimization criterion. This situation is also presented in the solution of the first test case.

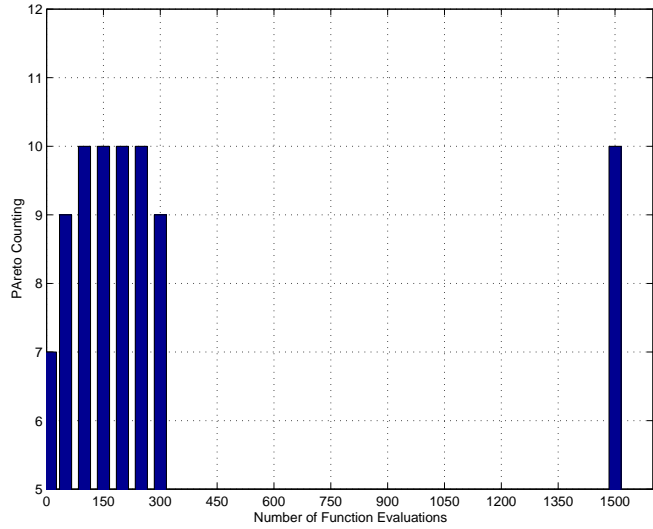

Figure 9: Average number of solutions in the Pareto Front vs Average number of function evaluations in MDQL.

This behavior can be attributed to the precision of float numbers, and to the discretization levels for the parameter space. The combination of these two factors causes a truncation of the variables, and consequently in the solutions. Reported solutions are the best from ten executions of the algorithm with the same operation parameters. In four of the ten executions *MDQL* converge to the same Pareto Front reported in Figure 8, in two executions only nine of the ten solutions reported were found and in four cases only eight solutions were found. Otherwise, the mean number of solutions in the Pareto Front (Pareto Counting) is presented in Figure 9.

The solutions obtained for the second test case make evident the advantages when more than one criteria are considered, as there is more flexibility to take a good decision. Additionally, and considering the type of problems exposed in this paper, the computational and analysis effort required to solve a problem with more than one criteria is not much greater than the required for the single objective case, but results are more valuable, from the point of view of information content.

Average CPU time taken by MDQL to obtain the Pareto Front presented in Figure 8 was around 20 seconds.

4.3 Water distribution system of Cuernavaca

The Cuernavaca city water distribution system, in México, operates as illustrated in Figure 10. There are three different types of sources of freshwater in the city, according to the National Water Commission (NWC): 42 water springs supplying 1,409 l/s , 328 deep wells with a contribution of 1,503.58 l/s , and water wheels contributing with 751.50 l/s ¹.

Water users are classified into five categories according to the water works user census. A brief description of the kind of exploitation given to water by each category is given below, accompanied with their freshwater demand taken from [21]. In order to be consistent with the nomenclature previously used, every category is considered as an unitary operation.

Self service: Users that have its own source to satisfy any kind of needs including human consumption. Water demand for this type of users is 1.36 l/s .

Industrial: Users exploiting water to operate only industrial processes in which there are no human needs to satisfy. Water demand for this unitary operation is 47.58 l/s .

Agriculture: Covers all the users exploiting freshwater only for irrigation. The main crops cultivated in the region of Cuernavaca are rice, corn, grass and rose trees. This is the second most water demanding operation in the system with 593.00 l/s .

Services: Users with high consumption rates, such as hotels, schools, restaurants, supermarkets, etc. Freshwater demand for this operations ascends to 16.19 l/s .

Urban & Public: Most of the domestic users in the city, including small schools, stores, public offices and small workshops. This is the most demanding operation with a demand of 3,003 l/s .

Multiple: Users not classified in any of the previous categories with an activity that can be classified as a service, but with less consumption rate. This operation demands 2.24 l/s .

¹It is important to note that the net extractions and run offs from the sources reported are greater because they also supply freshwater to other other towns close to Cuernavaca.

Table 7: Inflow and outflow limit concentration for all current operations in the city of Cuernavaca.

Operation O	BOD_5			TSS		
	$c_{i,A,in}^{max}$	$c_{i,A,out}^{max}$	$\Delta m_{i,tot}$	$c_{i,B,in}^{max}$	$c_{i,B,out}^{max}$	$\Delta m_{i,tot}$
	mg/l	mg/l	kg/h	mg/l	mg/l	kg/h
Urban & Public	0.00	220.00	1,767.74	0.00	220.00	1,403.07
Services	0.00	220.00	9.53	0.00	200.00	7.56
Agriculture	50.00	350.00	449.57	50.00	300.00	449.57
Multiple	0.00	220.00	1.32	0.00	220.00	1.05
Industrial	0.00	874.00	85.57	0.00	371.00	36.32
Self Service	0.00	220.00	0.60	0.00	240.00	0.73

It is relevant to note that part of the demanded water is consumed by the operation itself, another part cannot be registered and is considered as a loss caused by leaks occurring along the distribution systems. The rest is declared as wastewater and is supposedly discharged with the effluents to the receiving water bodies. For Cuernavaca city this body is the Apatlaco river. It is estimated that the water consumption and the flow lost in leaks is about 43.41% of the water demanded by operations [22]. This estimation is illustrated with the label ‘leaks & consumption’ in Figure 10 for every operation considered.

Two contaminants indexes are considered, in connection with the contaminants threw by the operations to the effluents, 5 day biochemical oxygen demand (BOD_5) and total suspended solids (TSS). These indexes are used in the general water quality index, according to the NOM-001-ECOL-1996 standard, which is the Mexican official standard for wastewater discharges. Wastewater treatment plants treat 339.15 l/s to BOD_5 and TSS mean concentration of 50 mg/l according to the data reported in the literature [3].

Values for both water quality indexes, $c_{i,k,out}^{max}$, were established using information from studies that evaluated the degree of contamination in the Apatlaco river [20]. For both contaminants, the concentration in the fresh-water supplied to the system is considered to be zero, see Table 7.

There are 15 wastewater treatment plants in Cuernavaca city, ten of those plants treat municipal wastewater while five plants are used for treatment of industrial wastewater. The total treated wastewater flow-rate is 364.15 l/s [20]. Table 8 shows the design and current operation treatment capacity for

Table 8: Cuernavaca city municipal and industrial wastewater treatment plant capacity[20].

	Design l/s	Operation l/s
Municipal Plant 1	15.00	13.00
Municipal Plant 2	27.00	9.00
Municipal Plant 3	38.00	13.00
Municipal Plant 4	1.70	1.50
Municipal Plant 5	0.16	0.15
Municipal Plant 6	400.00	300.00
Municipal Plant 7	4.00	3.00
Municipal Plant 8	8.00	0.00
Municipal Plant 9	10.00	0.00
Municipal Plant 10	8.00	0.00
Total	511.86	339.65
Industrial Plant 1	23.00	16.00
Industrial Plant 2	0.90	0.80
Industrial Plant 3	5.00	3.50
Industrial Plant 4	4.00	3.60
Industrial Plant 5	1.40	0.60
Total	34.50	24.50

the 15 plants in the city.

As can be seen, municipal plant 6 operates at 75% of its capacity, while the rest of the plants work at an average of 35.44% of their design capacity, treating only 39.65 l/s when they could treat 111.86 l/s . Since great quantities of wastewater can be treated with the same infrastructure, without the investment in new treatment plants, this can be seen as an opportunity area that can help to improve the system's performance.

Two strategies were evaluated to improve the performance of the system. The first one considers the operation of the treatment plants at their current operation capacity, that is 339.65 l/s , and the reduction of leaks in the distribution network from 43% to 25%. The second strategy considers the operation of the existing treatment plants at their design capacity, 511.86 l/s , a leak reduction program to decrease the non accounted water from 43% to 25%, and the construction of new additional water treatment plants to increase the treatment capacity in the city to 100%. The second strategy

was designed to improve the water quality in the receiving body according to the NOM-001-ECOL-1996 official standard, in this case the Apatlaco river.

4.3.1 Results for the first strategy

This strategy reduces Cuernavaca city water distribution network leaks from 43% to 25%. The waste water treatment plants operation maintain their current levels, that is, 339.65 l/s . Urban and public water demand is covered with 3,003 l/s from wells, springs and water wheels, but 1,291.6 l/s , that is, 43% of this demand is lost through domiciliary and network leaks (see Figure 10).

Results are presented in Figure 11. The main change in the operation of the water distribution network in Cuernavaca found by *MDQL* is to supply water for agriculture from three different sources: the mayor quantity from the wastewater treatment plants, followed by the freshwater and a minor quantity of wastewater from the urban and public sector. This operation guarantees acceptable levels of contaminant according to standards. The main water savings is obtained from the freshwater that is no longer supplied to agriculture. The results can be analyzed from two perspectives: a) increment of the irrigated area since there is an increment of water availability in the region, and b) reduction of freshwater sources exploitation with a benefit to the environment.

Analyzing the left most solution in Figure 11, which is shown in Figure 12, it can be seen that the total demanded freshwater flow-rate by the system is 2,752.6 l/s , representing a decrement of approximately 24.87 % (see Figure 10), that is, 911.57 l/s of the amount of water taken from the sources. As previously mentioned, the main change is in agriculture, for which water demand flow-rate could be satisfied with 339.65 l/s taken from wastewater treatment plants, 9,96 l/s with wastewater from the urban and public sector, and 234.15 l/s with fresh water taken from springs in the city.

This savings in freshwater can be used to increase the irrigated surface in about 511 ha of corn, 1,080 ha of beans, 219 ha of sugar cane, or 859 ha of onion, considering irrigation depths of 74, 35, 172, and 44 cm respectively.

On the other hand, freshwater savings represent approximately 28.74 millions of m^3 per year that could increase water availability in the Cuernavaca valley aquifer from eight millions of cubic meters to 36.74 millions of cubic meters.

Finally, it can be appreciated that the solution of the bi-objective model

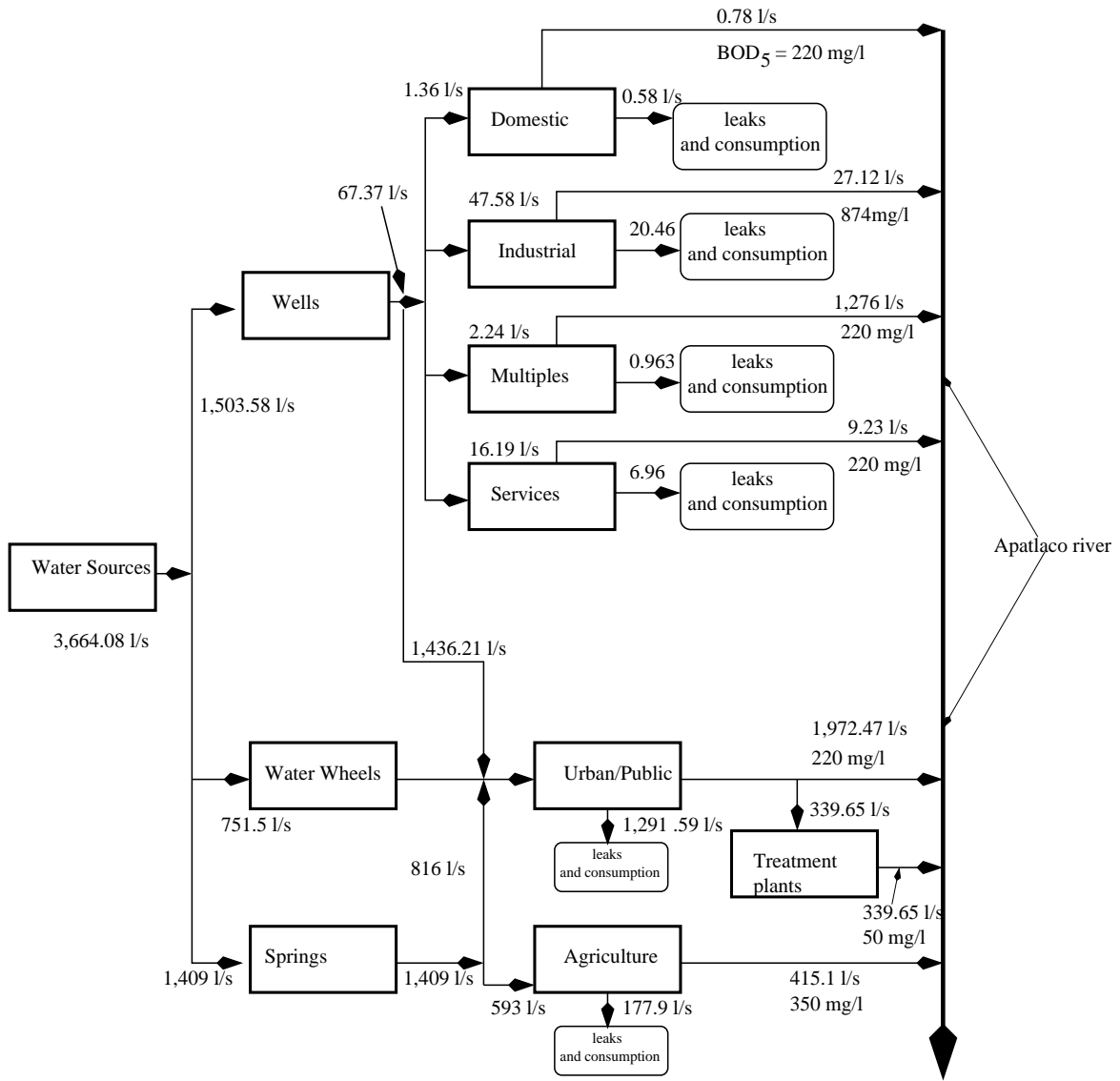

Figure 10: Current operation of the distribution system of the city of Cuernavaca, Mexico.

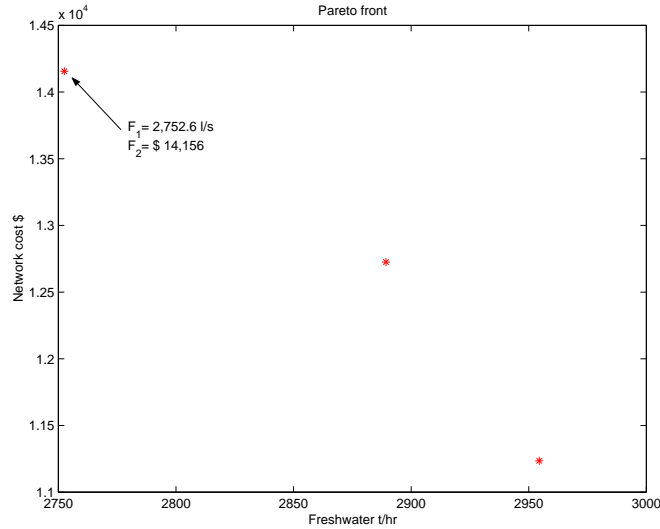

Figure 11: Cuernavaca city distribution system results for the first strategy.

for the case of the distribution network of Cuernavaca city with *MDQL* approach allows, the construction of a Pareto set with three optimal solutions. Only the left most one was analyzed in detail since it represents the lowest freshwater demand solution, but the same analysis can be made with the other two.

4.3.2 Results for the second strategy

The second operation strategy considers the operation of existing wastewater treatment plants to their design capacity, that is, treatment capacity is increased to 511.86 *l/s* with no investment cost. As in the previous strategy, a leak reduction to 25% is considered.

The Pareto front obtained for this test case is shown in Figure 13. *MDQL* was capable of finding four solutions. The left most solution with the lowest freshwater demand of 2,581.3 *l/s* and cost of \$1,796 is shown in Figure 15. The construction of two new wastewater treatment plants is proposed in this solution. The first proposed wastewater treatment plant capacity is 81.38 *l/s*. This proposed plant can receive 4.6 % of the discharged wastewater from the urban and public sector, and 53 % of the discharged water by the multiple sector.

The second proposed wastewater treatment plant capacity is 1,130.44 *l/s*

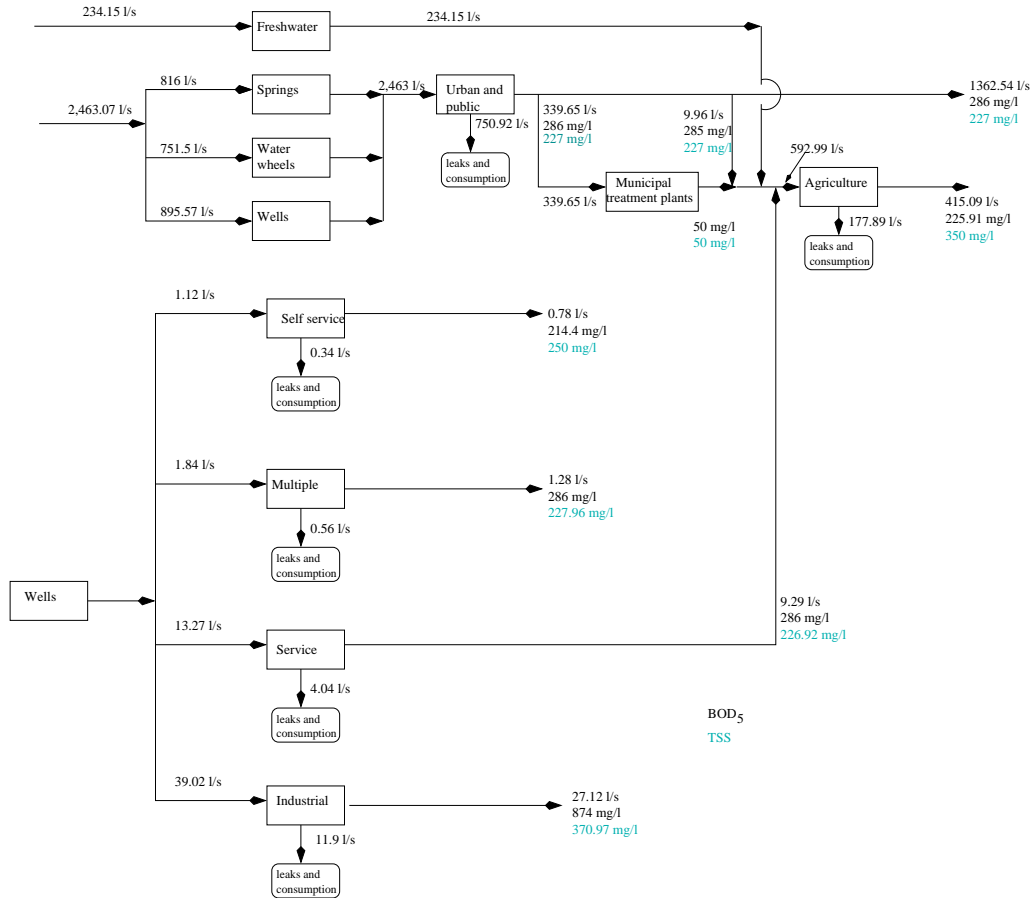

Figure 12: Solution with the lowest freshwater demand in the Pareto set found for the first strategy.

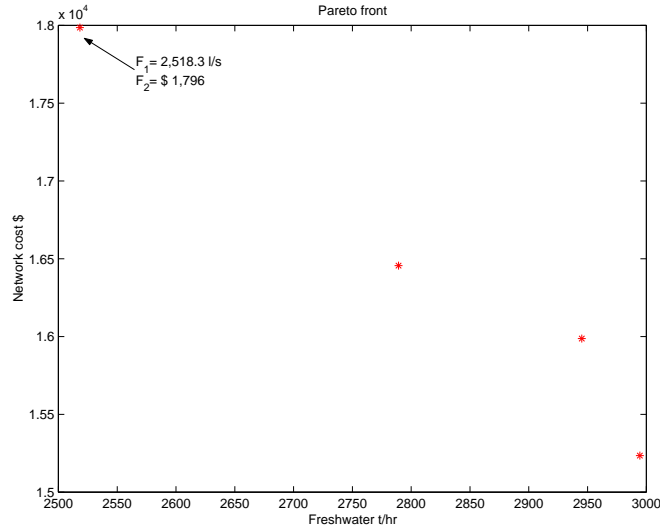

Figure 13: Cuernavaca city distribution system analysis results obtained by the second strategy.

and could receive the rest (95.4 %) of the discarded wastewater by the urban and public sector.

Similarly to the results found for the first strategy, demanded water by agriculture is satisfied with the total of the municipal treated water, and with 81.38 l/s coming from the new plant proposed in the design. Industrial water is treated independently in the existing industrial treatment plants.

Water savings arise since a considerable flow of freshwater is not longer supplied to the agriculture sector. This reduction represents an increase of the irrigated surface in the Cuernavaca valley of approximately 642 ha for corn, 1,357 ha for beans, 276 ha for sugar cane, or 1,080 ha for onion, with water depths of 74, 35, 172 and 44 cm, respectively. There are 34.15 millions of cubic meters per year of freshwater savings that could increment the freshwater availability of the aquifer from eight to 44.13 millions of cubic meters per year.

As can be seen from Figure 13, the left most solution is the lowest freshwater flow-rate demand solution of both strategies. It is also the highest cost solution, but at the same time all the discharged water by the Cuernavaca city water distribution system is treated so it represents the lowest contamination levels (see Figure 15 and Figure 12 wastewater discharges to the Apatlaco river). Qualitative, efficiency is measured in terms of the remaining contam-

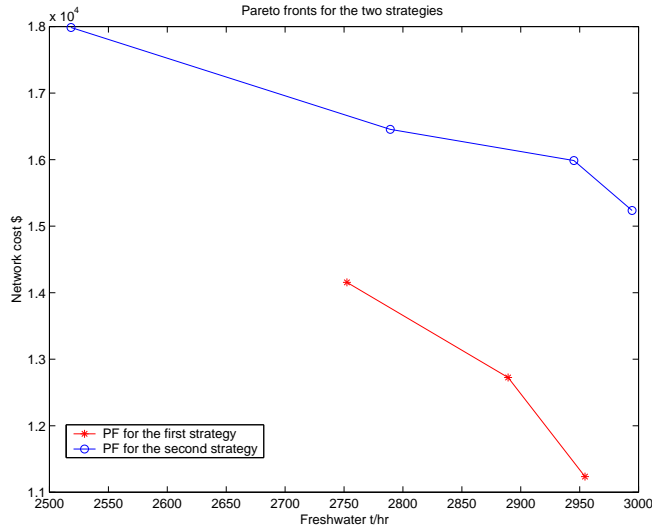

Figure 14: Comparison of the Pareto fronts obtained for the two strategies used for the Cuernavaca city water distribution system.

inant concentration in discharged wastewater to the reception bodies. This parameter is not included in the optimization model, but according to the environmental standards (included in the model) solutions for both strategies are feasible and do not violate them.

Figure 14 shows the Pareto fronts obtained with the two strategies and facilitates the analysis and decision making. It is desirable to construct graphs with Pareto fronts obtained from different strategies to appreciate potential benefits. In this case it is possible to evaluate that the solutions with the mayor benefit in terms of freshwater savings is obtained with the second strategy with a high cost (left most second strategy solution). As previously mentioned, solutions for the two strategies are in accordance with environmental standards, so, if cost is considered as the main criterion for decision making, a desirable solution could be the left most solution of the first strategy.

5 Conclusions

In this work we presented a multi-objective optimization problem for water distribution systems using water pinch technology criteria, we evaluated the

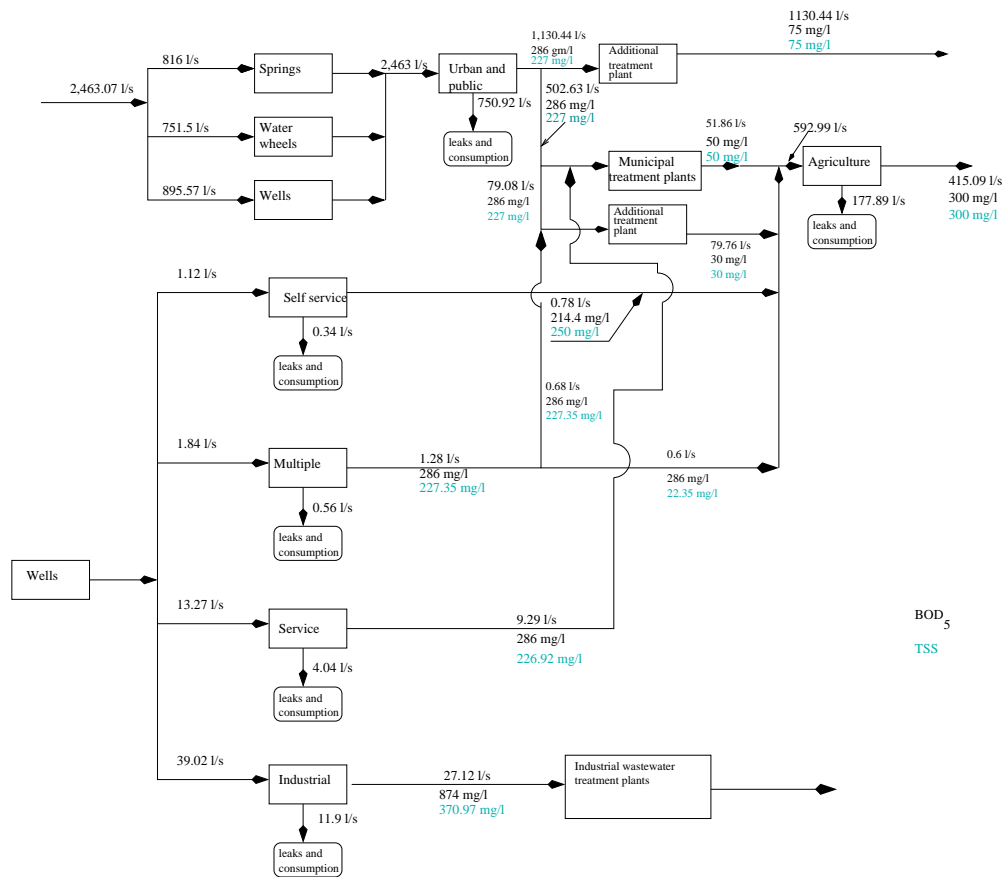

Figure 15: Solution with the lowest freshwater demand in the Pareto front found with the second strategy.

multi-objective optimization model, and we verified the capability of *MDQL* to solve complex real problems with highly restricted non convex spaces.

The water pinch optimization model considers more than one criteria. The model considers the reuse of wastewater from operations, wastewater treatment, consumption flow-rates and leaks in the system. With the reduction of freshwater demands it is possible to guarantee that the quality of the water served to the different users do not violate ecological and sanitary norms. The bi-objective optimization model operates considering mass balances between operations, freshwater sources, wastewater treatment plants, and wastewater disposal effluents. Contaminants loads from operations to water flows are restricted by environmental and operational constraints, resulting in a highly non linear model.

The proposed model was tested on three cases: (i) a four unitary operations and one contaminant; (ii) a real industrial process in the UK with ten unitary operations and four contaminants, and (iii) the Cuernavaca city water distribution operation system. A heuristic approach based on the solution of Markov decision processes, *MDQL*, was used to solve these cases. Although *MDQL* performance was previously measured on several benchmark problems [15, 16, 17] with very promising results, we wanted to verify its performance in the solution of highly restricted real problems. A weighted aggregated function was also used as a mean of comparison, selected on the basis of previous results and convergence properties reported in the literature [18].

The application of *MDQL* to the solution of water pinch problems with highly restricted non linear spaces makes evident that the algorithm is relatively robust. *MDQL* does not depend on complex codings or operators and its reinforcement learning approach allows it to improve its performance during the search process. We have already tested some of *MDQL*'s characteristics on a previous work [17]. Our results in a highly restricted real world application reinforces our hypothesis that learning during the search process is relevant to find good solutions for optimization problems.

Solutions to water pinch problems, represent important technical challenges that are only partially solved by the industry. The results presented here represent an example of how real applications can be solved with the participation of multidisciplinary teams involving researches from different communities, as in this case.

As future work we are considering implementing constraints to select more efficiently different processes. For example, if wastewater treatment technol-

ogy is selected in terms of the type of contaminants, the mass remotion could be made more effective and the system more efficient if the proper process is selected and optimized in terms of cost and efficiency. Another important aspect to implement is the cost function, which needs to be extended in order to quantify operation costs, reuse costs, and other economic factors affecting the operation of a system with these characteristics.

5.1 Future Research Work

In relation with the future work related with the optimization model presented in this paper, an extension of the model is being prepared. This extension considers the analysis in detail of the mass exchange in unitary operations opening the possibility to make dynamic analysis of the phenomenon. With the use of this extension it could be possible to make finer optimization of the process and to construct operation manuals to make the operation of systems optimal.

Acknowledgments

This work has been partially supported by CONACyT under grant ref 33000-A and the Mexican Institute of Water Technology. The authors wish to thank to Dr. Velitchko Tzatchkov and Veronica Soto for their technical comments and reviews.

References

- [1] Alcocer, V. and Arreguín, F., Minimización de agua de primer uso en procesos industriales a través de técnicas de optimización. *Memorias del XX Congreso Latinoamericano de Hidráulica*, La Habana, Cuba, september 2002, (in spanish).
- [2] Alva-Argaez, A *An Automated design tool for water and wastewater minimization*, PhD Thesis, Department of Process Integration University of Manchester IST, UK 1999.
- [3] Arreguín, C., F., Alcocer, Y. V. Modelación sistémica del uso eficiente del agua. *Revista Ingeniería Hidráulica en México*. Vol. XIX, No. 3, july, 2004.

- [4] Athan, T. and Papalombros P. A note on weighted criteria methods for compromise solutions in multi-objective optimization. *Engineering Optimization*, 27:155-176, 1996.
- [5] Bäck T. *Evolutionary algorithms in theory and practice*, Oxford University Press, 1996.
- [6] Coello, C. and Mariano, C., (2002) *Multiple criteria optimization. state of the art annotated bibliographic surveys*, Edited by Matthias Ehrgott, Xavier Gambibelux, Kluwer Academic Publishers, Chapter 6. *Evolutionary Algorithms and Multiobjective Optimization*, pp. 277-331.
- [7] Coetzer, D., Stanley, C. and Kumana, J. Systemic Reduction of Industrial Water Use and Wastewater Generation, In *Proc. of AIChE National Meeting*, Houston, March 1997.
- [8] Dorigo, M. (1992) *Optimization, Learning and Natural Algorithms*. Ph.D.Thesis, Politecnico di Milano, Italy, in Italian.
- [9] Dorigo M., V. Maniezzo and A. Colorni (1996). The Ant System: Optimization by a Colony of Cooperating Agents. *IEEE Transactions on Systems, Man, and Cybernetics-Part B*, 26(1):29-41
- [10] Galan, B., and Grossmann, I.E., Optimal Design of Distributed Wastewater Treatment Networks, *Ind. Eng. Chem. Res.*, 37:4036, 1998.
- [11] GAMS/MINOS <http://www.gams.com> General Algebraic Modeling System Development Corporation, (2001).
- [12] Gass S. and Saaty T., *The computational Algorithm for the Parametric Objective Function*, Naval Research Logistics Quarterly, 2 (1995).
- [13] Kuo, W.C. and Smith, R. Effluent treatment system design, *Chem Eng. Sci.*, 52:4273, 1997.
- [14] Mann, G.J. and Liu, Y.A. *Industrial Water reuse and wastewater minimization* McGrawHill Eds., 1999.
- [15] Mariano, C. and Morales, E., (2000) A new approach for the solution of multiple objective optimization problems based on reinforcement learning, *Lecture Notes in Artificial Intelligence, Proceedings of the Mexican*

- International Conference on Artificial Intelligence*, pp. 212-223, Aca-
pulco, Mex, April, 2000.
- [16] Mariano, C., (2001) *Reinforcement learning in multiobjective optimization* PhD Thesis in computer Science, Instituto Tecnológico y de Estudios Superiores de Monterrey, Campus Cuernavaca, March, 2002, Cuernavaca, Mor., México.
 - [17] Mariano, C. and Morales, E., (2001) A new updating strategy for reinforcement learning based on Q-learning, In P. Flach and L. de Raedt (eds.), *Springer Verlag, Lecture Notes in Artificial Intelligence, vol 2167: 12th European conference on Machine Learning*, pages 324-335, 2001.
 - [18] Miettinen K., *Nonlinear Multiobjective Optimization*, Kluwer Academic Publishers, (1999)
 - [19] National Water Commission, *Study of fees over wastewater discharge rights*, Annual Report, Diseños Hidráulicos e Ingeniería Ambiental, 1990 (In Spanish).
 - [20] National Water Commission, *Clasification estudy in the Apatlaco river*, Sanitation and Water Quality Department from the Morelos state office, 1996 (In Spanish).
 - [21] National Water Commission, *Hydro-geological update of the aquifer of Cuernavaca, state of Morelos* 1999, CNA 2000, (In Spanish).
 - [22] Ochoa, L., Bourguett, V. *Integral reduction of leaks*, Mexican Institute for Water Technology, National Water Commission, September 1998, (In Spanish)
 - [23] Puterman, M. *Markov Decision Processes Discrete Stochastic Dynamic Programming*, Wiley Series in Probability and Mathematical Statistic, (1994)
 - [24] Sutton R., and Barto G. *Reinforcement Learning An Introduction*, MIT Press, (1998).
 - [25] Watkins, C., Dayan, P., (1992) Q-Learning, *Machine Learning*, 3:279-292, 1992.

- [26] Zadeh L., (1963) Optimality and Non-Scalar-Valued Performance Criteria, *IEEE Transactions on Automatic Control*, 8, (1963), 59-60.